

UW SHEAR – HUGE CAPABILITY

Underwater cutting operation

NUCLEAR



GRADEL
www.gradel.lu

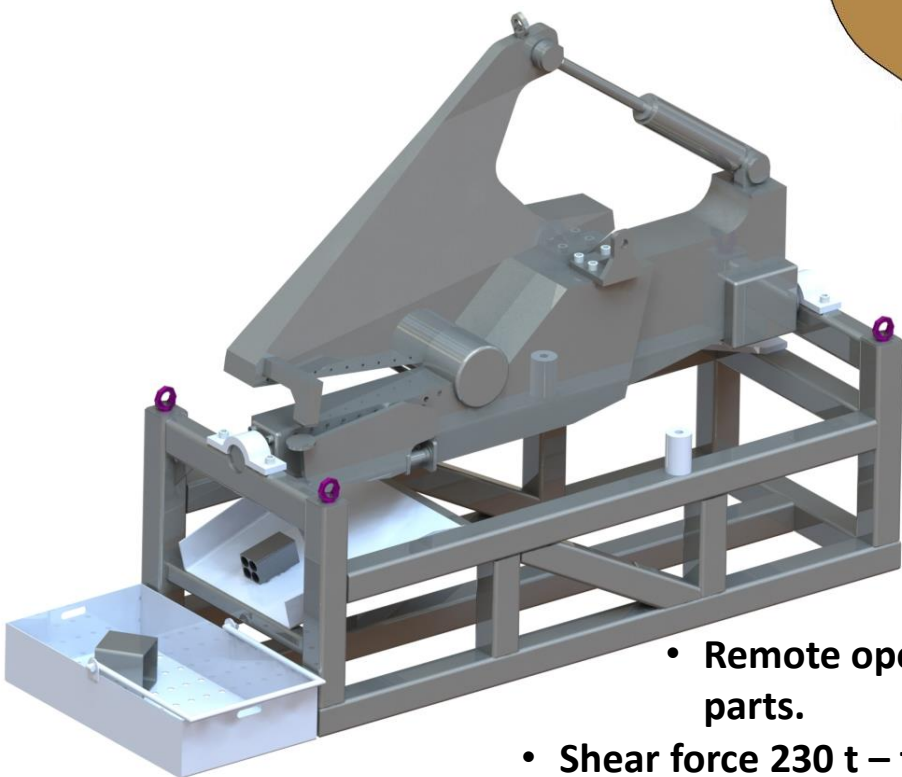
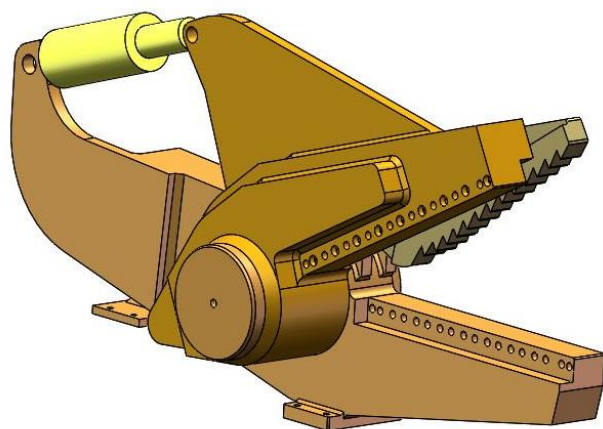

- Remote operation for cutting irradiated parts.
- Shear force 230 t – to cut element up to 470 mm height
- To cut rectangular aluminum tubes of 100 mm – rectangular stainless steel tubes of 200 mm thickness 8 mm
- For cutting of different profiles of complex shapes.

SHEAR – HUGE CAPABILITY

Underwater cutting operation

NUCLEAR



GRADEL
www.gradel.lu

- Handling under water using tool poles.
- Blades can be removed under water.
- Possibility of working with shears in horizontal and vertical position.

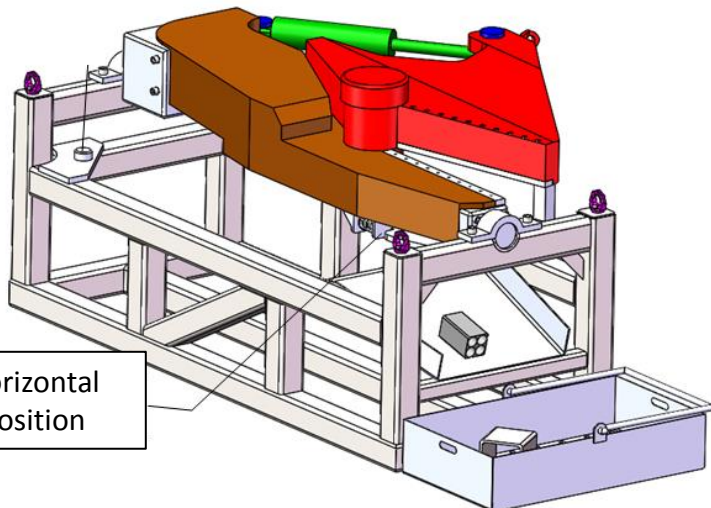

Horizontal
position

